

A Gene for Universal Congenital Alopecia Maps to Chromosome 8p21-22

Markus M. Nöthen,¹ Sven Cichon,¹ Ina R. Vogt,¹ Susanne Hemmer,¹ Roland Kruse,¹ Michael Knapp,² Tobias Höller,² Muhammad Faiyaz ul Haque,^{4,5} Sayedul Haque,⁴ Peter Propping,¹ Mahmud Ahmad,⁴ and Marcella Rietschel^{1,3}

¹Institute of Human Genetics, ²Institute for Medical Statistics, and ³Department of Psychiatry, University of Bonn, Bonn; ⁴Department of Biological Sciences, Quaid-i-Azam University, Islamabad, Pakistan; and ⁵Medical Genetics, Ahmanson Department of Pediatrics, Cedars-Sinai Research Institute, Los Angeles

Summary

Complete or partial congenital absence of hair (congenital alopecia) may occur either in isolation or with associated defects. The majority of families with isolated congenital alopecia has been reported to follow an autosomal-recessive mode of inheritance (MIM 203655). As yet, no gene has been linked to isolated congenital alopecia, nor has linkage been established to a specific region of the genome. In an attempt to map the gene for the autosomal recessive form of the disorder, we have performed genetic linkage analysis on a large inbred Pakistani family in which affected persons show complete absence of hair development (universal congenital alopecia). We have analyzed individuals of this family, using >175 microsatellite polymorphic markers of the human genome. A maximum LOD score of 7.90 at a recombination fraction of 0 has been obtained with locus D8S258. Haplotype analysis of recombination events localized the disease to a 15-cM region between marker loci D8S261 and D8S1771. We have thus mapped the gene for this hereditary form of isolated congenital alopecia to a locus on chromosome 8p21-22 (*ALUNC* [alopecia universalis congenitalis]). This will aid future identification of the responsible gene, which will be extremely useful for the understanding of the biochemistry of hair development.

Introduction

Congenital alopecia (also known as “congenital atrichia”) comprises localized as well as complete absence of hair and is present at or shortly after birth. Congenital

alopecia may occur either in isolation or with associated defects. On the basis of such associations, several different syndromes featuring congenital alopecia can be distinguished (Birnbaum and Baden 1987; Feinstein et al. 1987; Vogt et al. 1988). The isolated form of congenital alopecia has been reported in sporadic and familial cases. In familial cases, inheritance is usually autosomal recessive (MIM 203655 [<http://www3.ncbi.nlm.nih.gov:80/htbin-post/Omim/dispim?203655>]) (Baer 1907; Lundbäck 1944; Tillman 1952; Birke 1954; Cantú et al. 1980; Pinheiro and Freire-Maia 1985; Feinstein et al. 1987; Ahmad et al. 1993; Kenue and al-Dhafri 1994), but families with autosomal dominant (Pajtás 1950) or X-chromosomal recessive inheritance (MIM 300042 [<http://www3.ncbi.nlm.nih.gov:80/htbin-post/Omim/dispim?300042>]) (Anzai et al. 1996) have also been reported. Patients with the recessive form tend to have a more severe phenotype, often with complete absence of hair development, affecting all scalp and body hair (universal alopecia). Patients of the autosomal dominant type might be considered to have an early-onset form of dominantly inherited atrichia/hypotrichia, in which loss of hair is less complete and is usually not present at birth but develops in childhood or later.

Two of us (M.A. and S.H.) have elsewhere described a large inbred Pakistani family with autosomal recessive inheritance of isolated universal congenital alopecia (Ahmad et al. 1993). All the affected persons have a complete absence of scalp hair, as well as absence of hair in the axillary and pubic regions; eyebrows and eyelashes are also completely absent. The affected newborn infants have a few sparse hairs at the crown of head, which fall off within a few weeks and never regrow. Otherwise, the skin appears normal. Skin biopsy shows an unremarkable epidermis and dermis containing hair follicles without hair.

In order to map the locus associated with the alopecia trait, we performed a genomewide search with genotypes of microsatellite polymorphic markers in members of this Pakistani family. Markers within chromosome 8p21-22 showed no recombination with the phenotype.

Received August 6, 1997; accepted for publication November 11, 1997; electronically published February 6, 1998.

Address for correspondence and reprints: Dr. Markus M. Nöthen, Institute of Human Genetics, University of Bonn, Wilhelmstrasse 31, 53111 Bonn, Germany. E-mail: noethen@humgen.uni-bonn.de

© 1998 by The American Society of Human Genetics. All rights reserved. 0002-9297/98/6202-0024\$02.00

The maximum LOD score (Z_{\max}) was obtained with D8S258, at a recombination fraction (θ) of 0. These results serve as the first step toward cloning the defective gene.

Material and Methods

DNA Typing

After informed consent was obtained, EDTA-anticoagulated blood was collected from 9 affected and 23 non-affected family members. Lymphocyte DNA was extracted from blood by being salted out with saturated NaCl solution (Miller et al. 1988).

A random genomewide search for linkage was conducted by means of polymorphic short-tandem-repeat markers from the ABI PRISM Linkage Mapping Set (Applied Biosystems) and the MDC Microsatellite Mapping Set (provided by A. Reis and M. Jung, Max-Delbrück-Centrum for Molecular Medicine, Microsatellite Center, Berlin). LPL was taken from the work of Zuliani and Hobbs (1990), and all other markers from chromosomal region 8p21-22 were taken from the Génethon human genetic linkage map (Dib et al. 1996).

One oligonucleotide of each pair of primers was fluorescently labeled. The PCR reaction for each marker was performed in a 10- μ l volume containing 40 ng of genomic DNA, 5 pmol of each primer, 200 μ M of each dNTP, 50 mM KCl, 10 mM Tris-HCl (pH 8.3), 1.5–2.5 mM MgCl₂, and 0.6 U of *Taq* polymerase (Life Technologies). Reactions were performed in 96-well microtiter plates by means of a Perkin-Elmer 9600 thermocycler and consisted of an initial denaturation at 94°C for 5 min, followed by 33 cycles of denaturation at 94°C for 15 s, annealing at 55°C–60°C for 15 s (temperature was dependent on the primers used), and elongation at 72°C for 30 s. The final step consisted of an additional elongation step at 72°C for 5 min. After amplification, 1–2 μ l of each reaction were pooled, depending on size and fluorescent label. An aliquot equivalent to 0.2 μ l of each marker was removed, and 1 fmol of an internal size standard (Genescan 500-TAMRA; Applied Biosystems) in blue formamide was added. Samples were denatured at 94°C for 3 min and then were separated by electrophoresis on 4% (w/v) denaturing polyacrylamide gels by means of a model 377 Applied Biosystems automatic sequencer. GeneScan Analysis 2.0.0 and Genotyper version 2.0 software was used to size the PCR products and to analyze the data.

Linkage Analysis

Two-point analyses were calculated by means of the MLINK and ILINK programs of the LINKAGE package (Lathrop et al. 1984), as implemented in FASTLINK (version 2.2) (Cottingham et al. 1993; Schäffer et al.

1994). For these analyses, an autosomal recessive mode of inheritance and a disease-allele frequency of .01 were used. Since marker-allele frequencies for the Pakistani population are unknown, equal marker-allele frequencies were assumed. For the marker yielding the two-point Z_{\max} with the disease, the effect of this assumption was challenged by repeating the analysis, with a frequency of .9 being assigned to the marker allele that apparently segregates together with the disease allele (see the Results section). Because of the computational limits induced by the complexity of consanguineous loops, the two-point analyses required us to disregard two loops still present in figure 1, by ignoring the relatedness of individuals III-11 and III-42 with their respective mates, thus treating both persons as founders.

Results

A genomewide search using highly informative polymorphic markers was performed on DNA from the members of a large inbred Pakistani family with isolated universal congenital alopecia (Ahmad et al. 1993). The pedigree used in the present study is illustrated in figure 1. Thirty-two family members were available for genotyping. A total of 175 markers were used, until identification of the marker, D8S258, that showed no recombination with the phenotype. Subsequently, only markers on chromosome 8 were used. Results of two-point pairwise analyses of the phenotype of congenital alopecia and chromosome 8 markers, at various θ values, are shown in table 1. A two-point Z_{\max} of 7.90 was obtained, with D8S258, at $\theta = 0$. As noted above, the LOD scores in table 1 are based on the assumption of equal marker-allele frequencies. For marker D8S258, the LOD score drops to 4.43 when a frequency of .9 is assigned to allele 1. Thus, the magnitude of the LOD score is sensitive to the assumed marker-allele frequencies, but the observation of linkage is still robust.

The haplotypes that define the most likely chromosomal interval for the disease-causing gene are indicated in figure 2. The marker order is D8S550–D8S552–D8S261–LPL–D8S258–D8S280–D8S282–D8S560–D8S1752–D8S1771–D8S1809–D8S283–D8S285. For these markers the most telomeric recombinant marker is D8S261. The most centromeric recombinant marker is D8S1771. This defines a 15-cM interval on the Génethon map (Dib et al. 1996). Our results localize the gene for isolated congenital alopecia to a 15-cM region between D8S261 and D8S1771 on chromosome 8p21-22.

Discussion

We have used linkage analysis to localize a gene for autosomal recessive congenital alopecia to the short arm

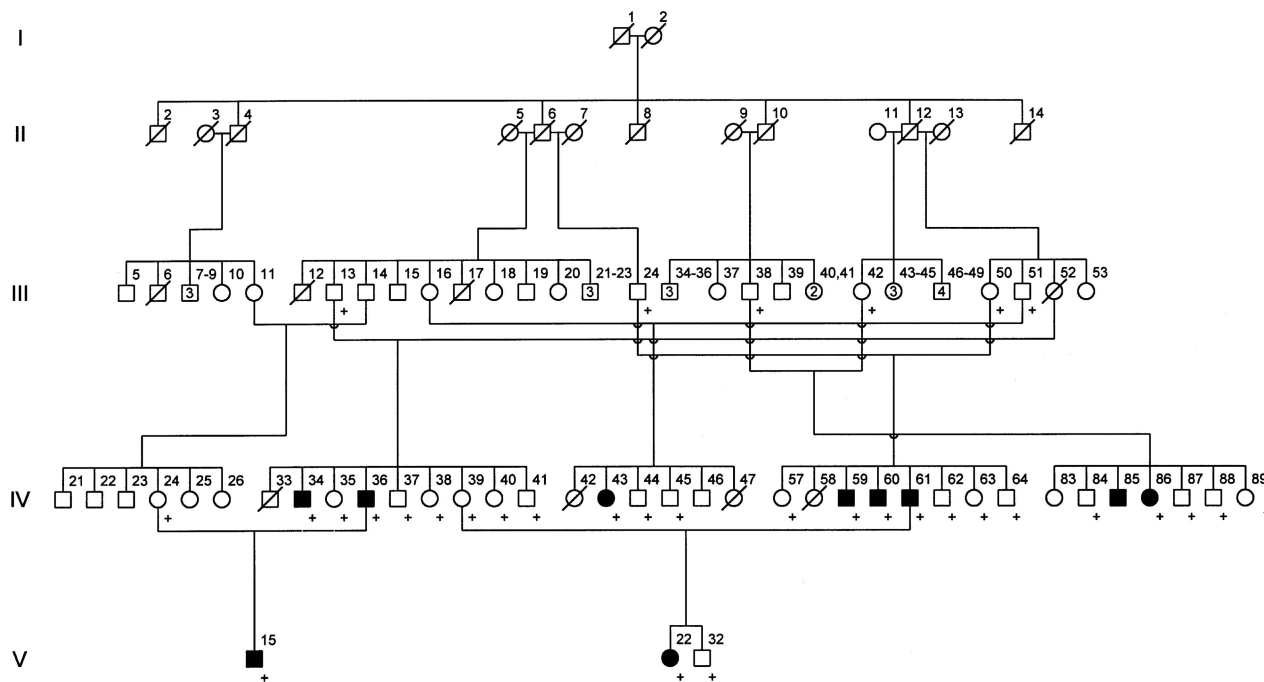

Figure 1 Abridged pedigree of the large inbred Pakistani family used in the present study. Numbering of individuals is that of Ahmad et al. (1993). Squares and circles denote males and females, respectively; blackened symbols denote affected individuals; and unblackened symbols denote unaffected individuals. A plus sign (+) below an individual indicates that DNA is available from that person.

of chromosome 8. This locus (designated “ALUNC”) is distinct from the locus for another primary hair disorder—namely, autosomal dominantly inherited monilethrix, on chromosome 12q13 (Healy et al. 1995). This is not unexpected, since, although severely affected indi-

viduals with monilethrix have near-universal alopecia, the dystrophic hairs in monilethrix have a unique beaded morphology that is not observed in isolated congenital alopecia.

In patients with autosomal recessive congenital alo-

Table 1
Two-Point LOD Scores, between the Disease Locus and 13 Chromosome 8 Microsatellite Markers

MARKER	GENETIC-MAP LOCATION ^a (cM)	LOD SCORE AT $\theta =$					MAXIMUM θ	Z_{max}
		.00	.01	.05	.10	.20		
D8S550	23	−∞	−3.10	.29	1.39	1.82	.19	1.83
D8S552	29	−∞	−2.53	.82	1.86	2.17	.17	2.19
D8S261	39	−∞	3.38	3.72	3.55	2.86	.05	3.72
LPL	...	4.16	4.08	3.74	3.33	2.50	0	4.16
D8S258	44	7.90	7.76	7.18	6.44	4.88	0	7.90
D8S280	44	2.93	2.87	2.61	2.29	1.64	0	2.93
D8S282	45	3.81	3.73	3.42	3.02	2.23	0	3.81
D8S560	46	4.93	4.84	4.46	3.99	3.00	0	4.93
D8S1752	49	5.23	5.13	4.74	4.23	3.19	0	5.23
D8S1771	54	−∞	3.79	4.38	4.26	3.42	.06	4.39
D8S1809	58	2.85	2.79	2.54	2.23	1.62	0	2.85
D8S283	60	3.11	3.25	3.41	3.28	2.65	0	3.11
D8S285	71	−∞	−2.14	−.54	.05	.38	.23	.40

^a Measured from 8pter and taken from the Généthon sex-averaged linkage map (Dib et al. 1996). LPL was placed between D8S261 and D8S258, on the basis of results of physical mapping experiments (Bookstein et al. 1994).

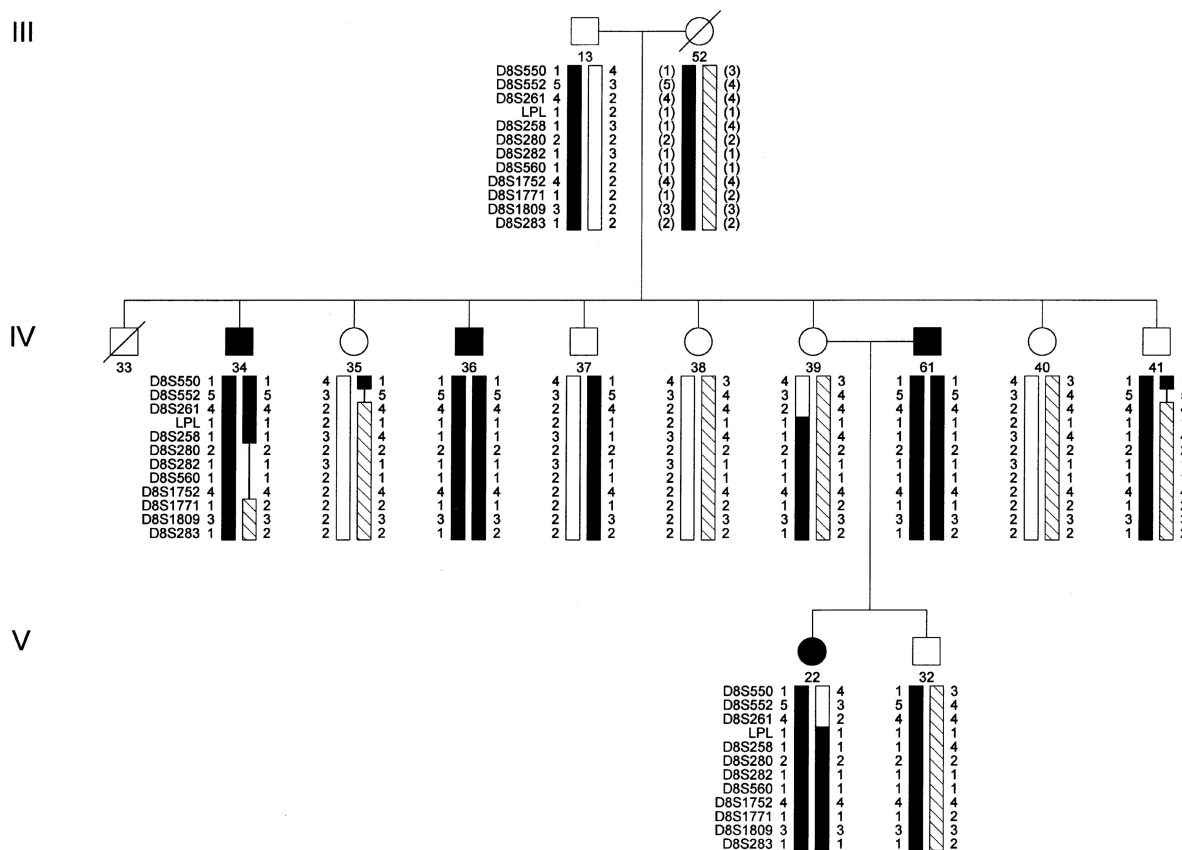

Figure 2 Abridged pedigree showing segregating haplotypes for chromosome 8 markers and critical recombinations. Symbols are as defined in the legend to figure 1. Blackened bars denote segregating chromosomal segments and show regions of crossover, and vertical lines denote noninformative regions adjacent to critical recombination events. Haplotypes in parentheses are inferred.

pecia, a broad spectrum of follicle alterations is observed. In our Pakistani kindred, a skin biopsy from an affected person shows hair follicles without hairs, whereas complete absence of hair follicles has been reported in patients from other families (Cantú et al. 1980; Kenue and al-Dhafri 1994). This may point to an etiologic heterogeneity within this inherited group of congenital alopecia, which remains to be investigated by the study of other families.

No clear candidate genes have been identified in the chromosomal region 8p21-22. Among the several genes mapped in this region, the heregulin gene (*HGL*) and the farnesyltransferase alpha gene (*FNTA*) could be envisaged as candidates for the disease (Holmes et al. 1992; Anders et al. 1993).

Heregulin is a ligand at the ERBB2(NEU) receptor tyrosine kinase, which is closely related to the epidermal growth-factor receptor (EGFR). Heregulin, also termed “NEU differentiation factor,” provokes receptor dimerization and, often, heterodimerization between different members of the EGFR family and increases the auto-phosphorylation of the receptor tyrosine kinase (Spivak-

Kroizman et al. 1992). A mutation in the *HGL* gene thus could have a negative effect on dimerization and autophosphorylation not only of the ERBB2(NEU) receptor but also of other members of the EGFR family and their following, signaling pathways.

The *FNTA* gene encodes an enzyme that is involved in posttranslational modification of a variety of cellular proteins, including p21ras. Farnesyltransferase alpha is known to be a specific cytoplasmatic interactor of the transforming-growth-factor beta (TGF-β) receptor, whose ligand TGF-β is a potent regulator of cell growth and differentiation (Wang et al. 1996).

Our knowledge of the molecular mechanisms responsible for hair-follicle development is incomplete, but there is some evidence that growth factors and their receptors exert a significant influence on the formation of hair follicles and on the growth of hair. It has been demonstrated that the expression of a dominant negative mutant of *EGFR* in transgenic mice leads to alterations in hair-follicle development, implying that it has a role as a positive regulatory factor in hair biology. High doses of its ligand EGF, however, inhibit hair-follicle devel-

opment and lead to loss of hair in in vitro experiments (Philpott et al. 1991; Murillas et al. 1995). In addition, other factors have been suggested to be involved in hair-follicle development and in cyclic hair growth, including the transforming growth factors and bone morphogenetic proteins, as members of the transforming-growth-factor superfamily, as well as cell-adhesion molecules such as the cadherins. Alopecia congenita may be caused by a change in these or other regulatory elements involved in hair-follicle development and in expression of hair proteins.

In conclusion, in this study we have described the first locus for isolated congenital alopecia in humans, which should allow the identification of the responsible gene. This will be extremely useful to the understanding of the biochemistry of hair development.

Acknowledgments

We are extremely grateful to all members of the family who participated in this work. We thank Prof. Gebhard Flatz for his help in establishing our collaborative study, Prof. Margaret H. Hardy for critical reading of the manuscript, and Markus Pützstück for technical assistance.

References

- Ahmad M, Abbas H, Haque S (1993) Alopecia universalis as a single abnormality in an inbred Pakistani kindred. *Am J Med Genet* 46:369-371
- Anders DA, Milatovich A, Ozcrlik T, Wenzlau JM, Brown MS, Goldstein JL, Francke U (1993) cDNA cloning of the two subunits of human CAAX farnesyltransferase and chromosomal mapping of FNTA and FNTB loci and related sequences. *Genomics* 18:105-112
- Anzai H, Shimizu H, Nishikawa T (1996) X-linked recessive inheritance in a family with isolated congenital alopecia. *Lancet* 347:337-338
- Baer T (1907) Zur Kasuistik der Hypotrichosis congenita familiaris. *Arch Dermatol Syph* 84:15-18
- Birke G (1954) Über Atrichia congenita und ihren Erbgang. *Arch Dermatol Syph* 197:322-343
- Birnbaum PS, Baden HP (1987) Heritable disorders of hair. *Dermatol Clin* 5:137-153
- Bookstein R, Levy A, MacGrogan D, Lewis TB, Weissenbach J, O'Connell P, Leach AJ (1994) Yeast artificial chromosome and radiation hybrid map of loci in chromosome band 8p22, a common region of allelic loss in multiple human cancers. *Genomics* 24:317-323
- Cantú JM, Sánchez-Corona J, González-Mendoza A, Martínez y Martínez R, García-Cruz D (1980) Autosomal recessive inheritance of atrichia congenita. *Clin Genet* 17:209-212
- Cottingham RW, Idury RM, Schäffer AA (1993) Faster sequential genetic linkage computations. *Am J Hum Genet* 53:252-263
- Dib C, Fauré S, Fizames C, Samson D, Drouot N, Vignal A, Millasseau P, et al (1996) A comprehensive genetic map of the human genome based on 5,264 microsatellites. *Nature* 380:152-154
- Feinstein A, Engelberg S, Goodman RM (1987) Genetic disorders associated with severe alopecia in children: a report of two unusual cases and a review. *J Craniofac Genet Dev Biol* 7:301-310
- Healy E, Holmes SC, Belgaid CE, Stephenson AM, McLean WHI, Rees JL, Munro CS (1995) A gene for monilethrix is closely linked to the type II keratin gene cluster at 12q13. *Hum Mol Genet* 4:2399-2402
- Holmes EW, Sliwkowski MX, Akita RW, Henzel WJ, Lee J, Park JW, Yansura D, et al (1992) Identification of heregulin, a specific activator of p185erbB2. *Science* 256:1205-1210
- Kenue RK, al-Dhafri KS (1994) Isolated congenital atrichia in an Omani kindred. *Dermatology* 188:72-75
- Lathrop GM, Lalouel JM, Julier C, Ott J (1984) Strategies for multilocus linkage analysis in humans. *Proc Natl Acad Sci USA* 81:3443-3446
- Lundbäck H (1944) Total congenital hereditary alopecia. *Acta Dermatol Venereol* 25:189-206
- Miller SA, Dykes DD, Polesky HF (1988) A simple salting out procedure for extracting DNA from human nucleated cells. *Nucleic Acids Res* 16:1215
- Murillas R, Larcher F, Conti CJ, Santos M, Ullrich A, Jorcano JL (1995) Expression of a dominant negative mutant of epidermal growth factor receptor in the epidermis of transgenic mice elicits striking alterations in hair follicle development and skin structure. *EMBO J* 14:5216-5223
- Pajtás J (1950) Totale familiäre Hypotrichose in 4 Generationen. *Dermatologica* 101:90-93
- Philpott MP, Westgate GE, Kealy T (1991) An in vitro model for the study of human hair growth. *Ann NY Acad Sci* 642:148-164
- Pinheiro M, Freire-Maia N (1985) Atrichias and hypotrichoses: a brief review with description of a recessive atrichia in two brothers. *Hum Hered* 35:53-55
- Schäffer AA, Gupta SK, Shiram K, Cottingham RW (1994) Avoiding recomputation in linkage analysis. *Hum Hered* 44:225-237
- Spivak-Kroizman T, Rotin D, Pinchasi D, Ullrich A, Schlesinger J, Lax I (1992) Heterodimerization of c-erbB2 with different epidermal growth factor receptor mutants elicits stimulatory or inhibitory responses. *J Biol Chem* 267:8056-8063
- Tillman WG (1952) Alopecia congenita: report of two families. *Br Med J* 2:428
- Vogt BR, Traupe H, Hamm H (1988) Congenital atrichia with nail dystrophy, abnormal facies, and psychomotor development in two siblings: a new autosomal recessive syndrome? *Pediatr Dermatol* 5:236-242
- Wang T, Danielson PD, Li B, Shah PC, Kim SD, Donahoe PK (1996) The p21ras farnesyltransferase alpha subunit in TGF- β and activin signaling. *Science* 271:1120-1122
- Zuliani G, Hobbs HH (1990) Dinucleotide repeat polymorphism at the 3' end of the LDL receptor gene. *Nucleic Acids Res* 18:4300